



YJQ5D7G04HHQ

N-Channel Enhancement Mode Field Effect Transistor

Product Summary

General Description

Applications

Absolute Maximum Ratings

Parameter	Symbol	Limit	Unit



Typical Electrical and Thermal Characteristics Diagrams

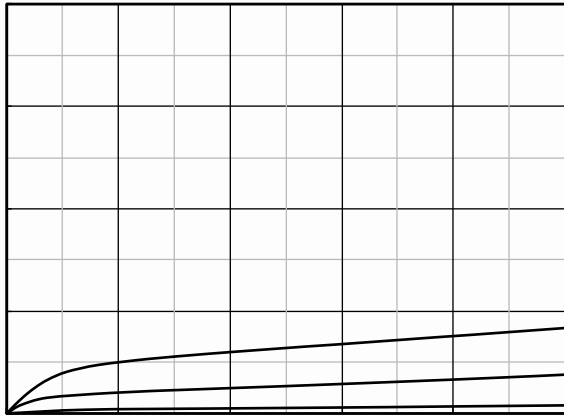



YJQ5D7G04HHQ

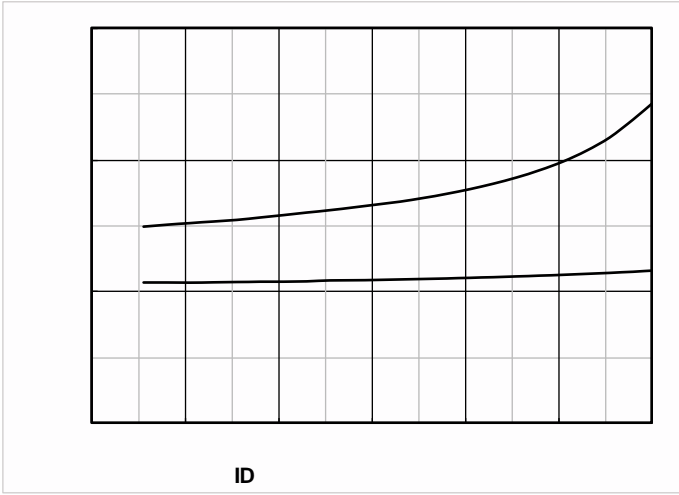



YJQ5D7G04HHQ

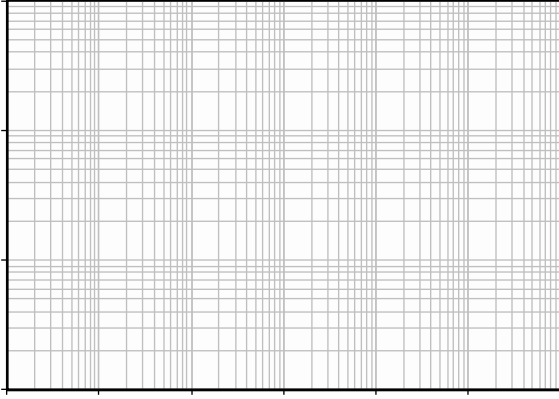



YJQ5D7G04HHQ

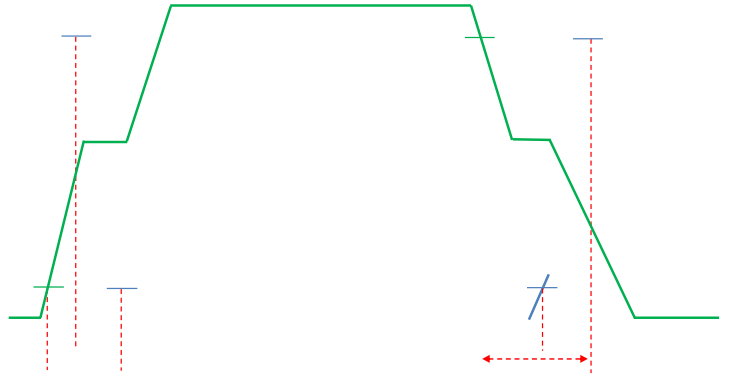
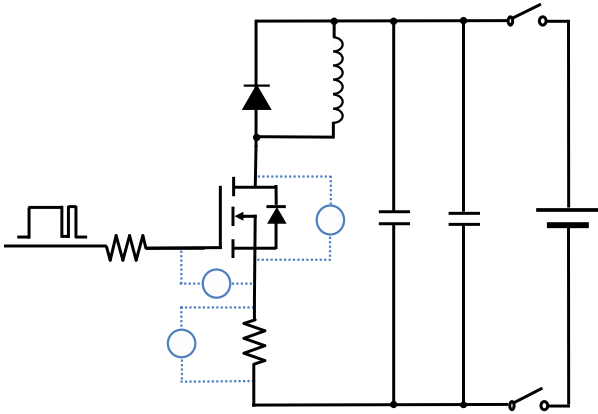
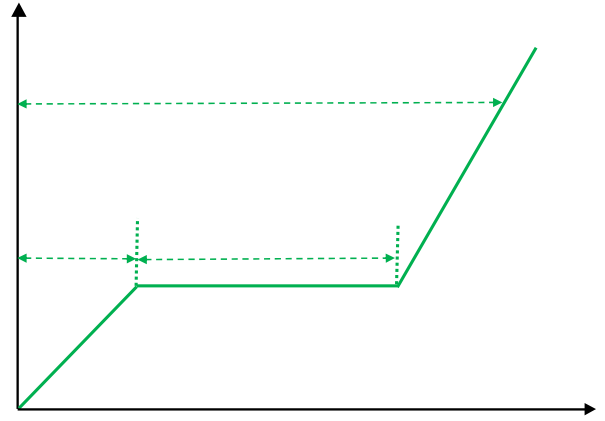
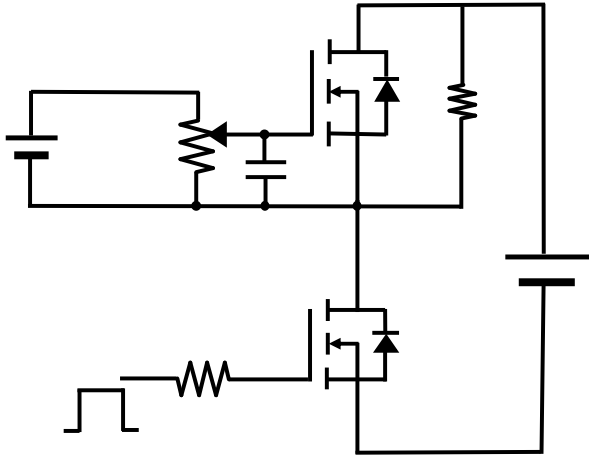



YJQ5D7G04HHQ

PDFN3333-8L-B-0.75MM Package information

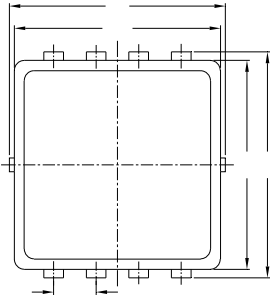

TOP VIEW

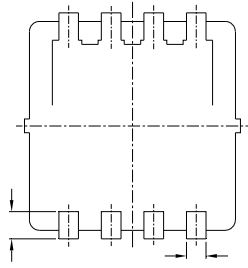

BOTTOM VIEW

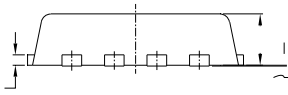

SIDE VIEW

SUGGESTED SOLDER PAD LAYOUT



YJQ5D7G04HHQ

Disclaimer



YJQ5D7G04HHQ
