



# YJD18G15A

---

## N-Channel Enhancement Mode Field Effect Transistor

### Product Summary

$V_{DS}$	150V
$I_D$	18A
$R_{DS(ON)}$ ( at $V_{GS}=10V$ )	70m
$R_{DS(ON)}$ ( at $V_{GS}=6V$ )	80m
100% EAS Tested	





# YJD18G15A

## Typical Electrical and Thermal Characteristics Diagrams

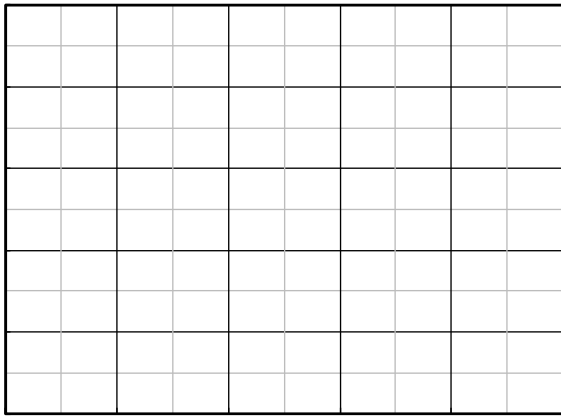

Figure 1. Output Characteristics

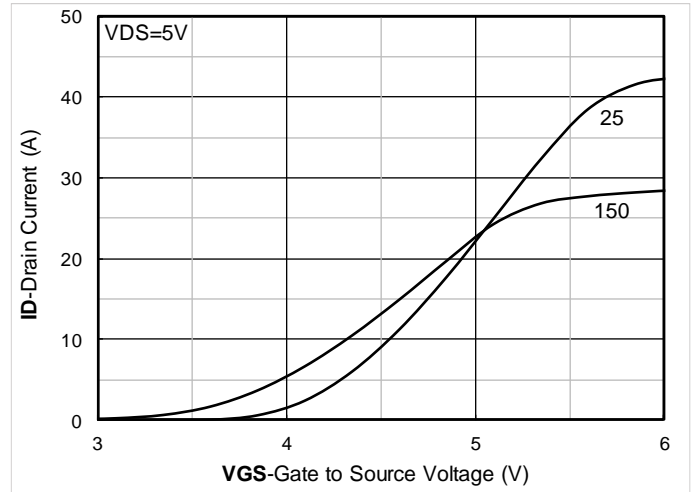

Figure 2. Transfer Characteristics

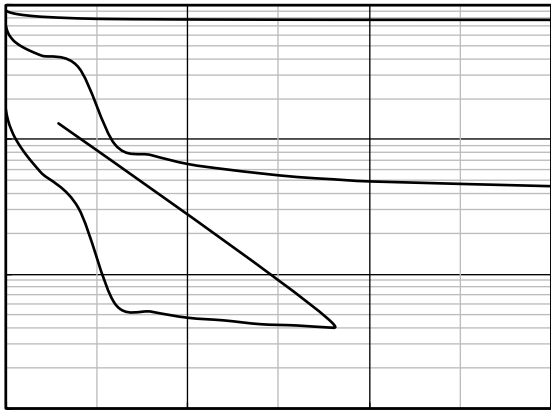

Figure 3. Capacitance Characteristics

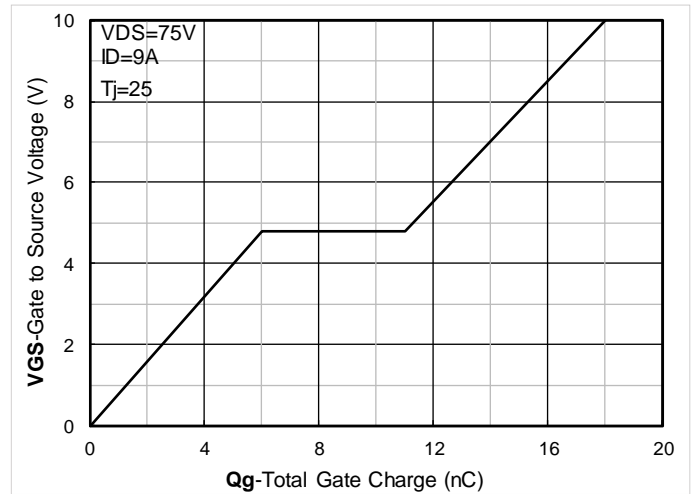

Figure 4. Gate Charge

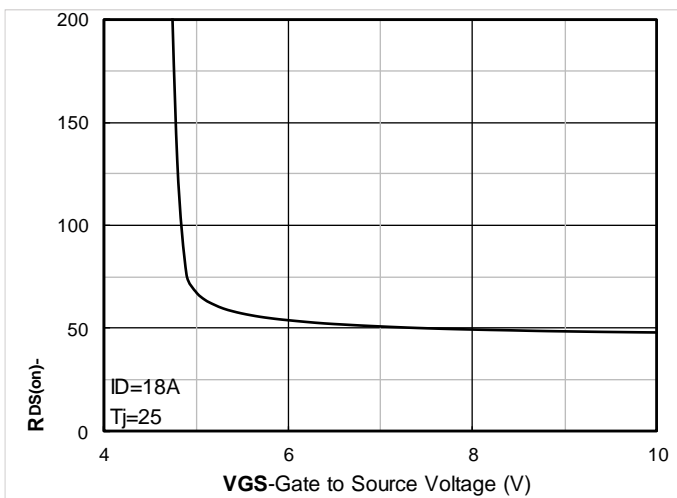

Figure 5. On-Resistance vs Gate to Source Voltage

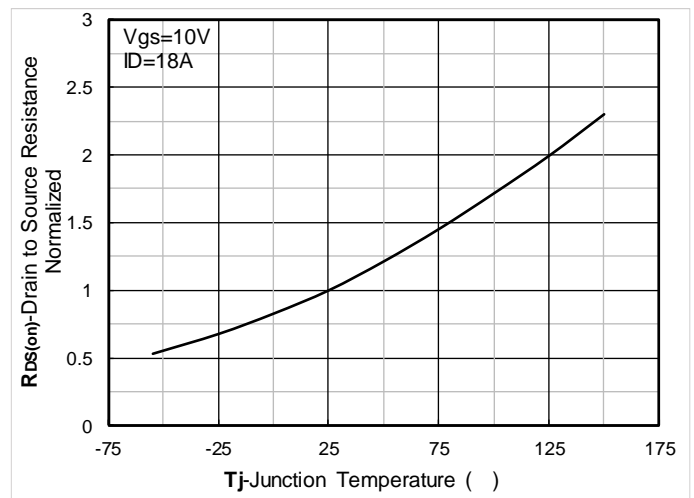

Figure 6. Normalized On-Resistance



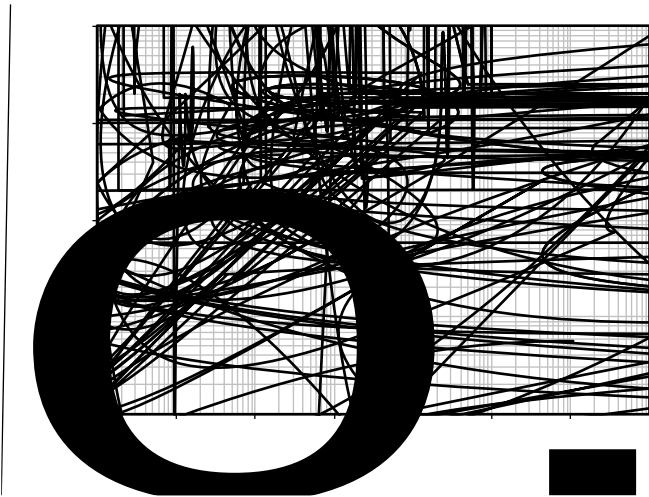

Figure 13. Maximum Transient Thermal Impedance

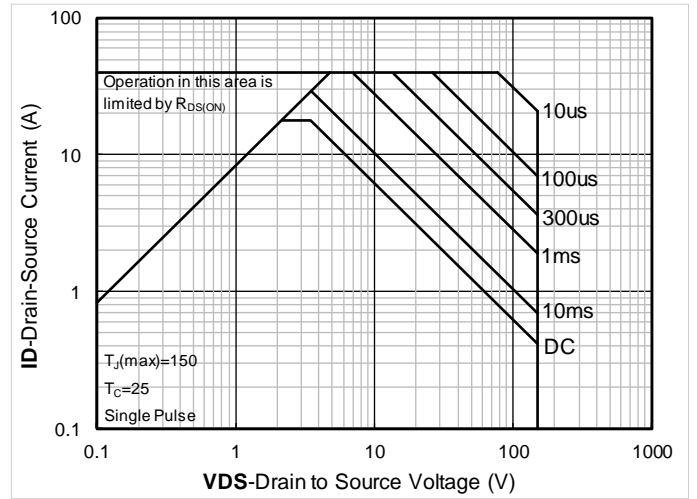

Figure 14. Safe Operation Area

## Test Circuits & Waveforms

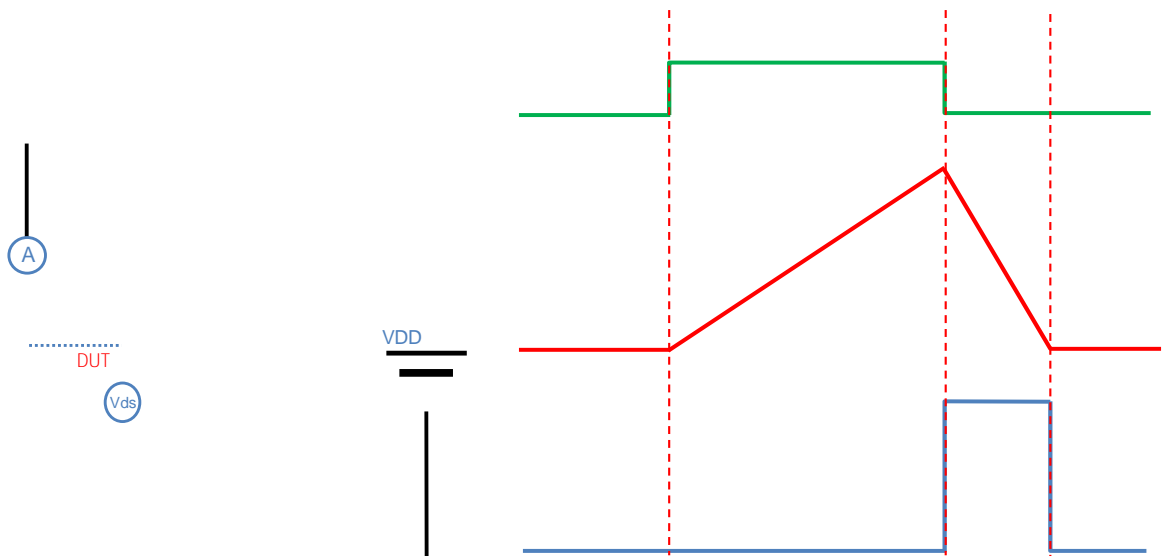

Figure A. Unclamped Inductive Switching (UIS) Test Circuit & Waveform



Figure B. Gate Charge Test Circuit & Waveform

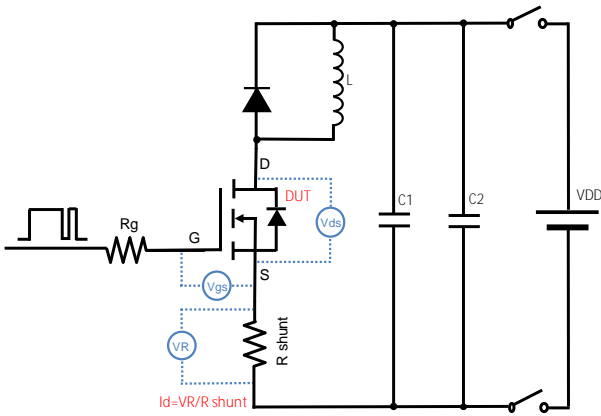

Figure C. Resistive Switching Test Circuit & Waveform

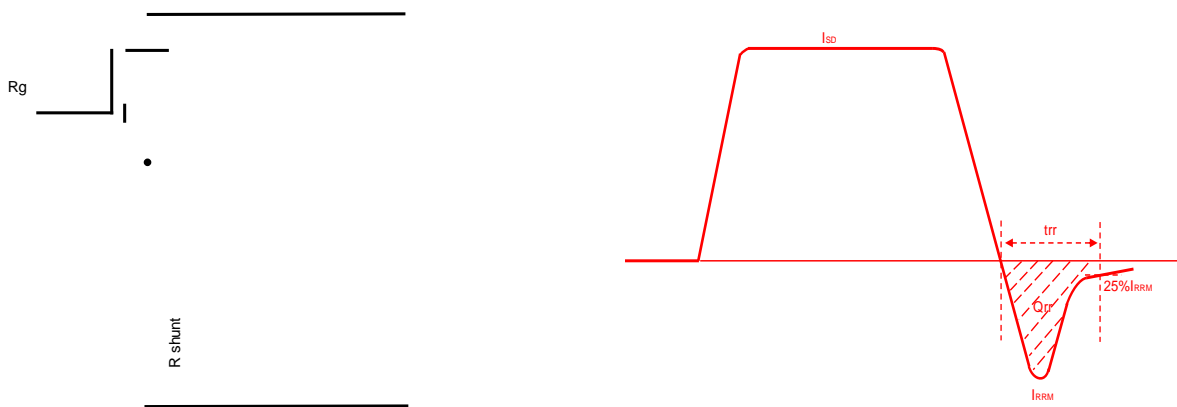
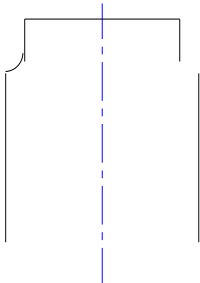
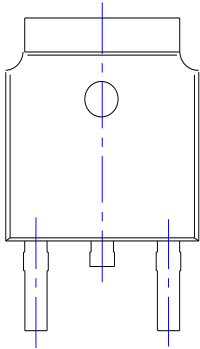

Figure D. Diode Recovery Test Circuit & Waveform



# YJD18G15A

## TO-252-B Package information



SYMBOL	DIMENSIONS				
	INCHES				
	MIN.	NOM.			
A1	0.000				
A2	0.087	0.091			
A3	0.035	0.039			
b	0.026	0.030			
c	0.018	0.020			
D	0.256	0.260			
D1					
D2	0.181	0.189			
E	0.390	0.398			
E1	0.236	0.240			

**NOTE:**

- 1.PACKAGE BODY SIZES EXCLUDE MOLD FLASH AND GATE BURRS.
- 2.TOLERANCE 0.1mm UNLESS OTHERWISE SPECIFIED.
- 3.THE PAD LAYOUT IS FOR REFERENCE PURPOSES ONLY.



# YJD18G15A

---

## Disclaimer

The information presented in this document is for reference only. Yangzhou Yangjie Electronic Technology Co., Ltd. reserves the right to make changes without notice for the specification of the products displayed herein to improve reliability, function or design or otherwise.

The product listed herein is designed to be used with ordinary electronic equipment or devices, and not designed to be used with equipment or devices which require high level of reliability and the malfunction of which would directly endanger human life (such as medical instruments, transportation equipment, aerospace machinery, nuclear-reactor controllers, fuel controllers and other safety devices), Yangjie or anyone on its behalf, assumes no responsibility or liability for any damages resulting from such improper use of sale.

This publication supersedes & replaces all information previously supplied. For additional information, please visit our website <http://www.21yangjie.com>